

### GENERAL CHARACTERISTICS

Nominal Overall Diameter .....	307	mm
Nominal Voice Coil Diameter .....	50	mm
Magnet Weight .....	200	g
Flux Density.....	1.20	T

### THIELE-SMALL PARAMETERS

Voice Coil DC Resistance .....	$R_E$	6.73	Ω
Resonance Frequency .....	$f_s$	92.0	Hz
Mechanical Q Factor.....	$Q_{MS}$	15.11	
Electrical Q Factor.....	$Q_{ES}$	0.74	
Total Q Factor .....	$Q_{TS}$	0.71	
Mechanical Moving Mass .....	$M_{MS}$	25.1	g
Mechanical Compliance .....	$C_{MS}$	119	μm/N
Force Factor .....	$B \times l$	11.47	Wb/m
Equivalent Acoustic Volume.....	$V_{AS}$	40.4	lt.
Maximum Linear Displacement ....	$X_{MAX}$	1.0	mm
Reference Efficiency .....	$\eta_0$	4.07	%
Diaphragm Area .....	$S_D$	490.9	cm <sup>2</sup>
Losses Electrical Resistance.....	$R_{ES}$	137.0	Ω
Voice Coil Inductance @ 1kHz .....	$L_E$	0.65	mH

### CONSTRUCTIVE CHARACTERISTICS

Magnet.....	Neodymium
Voice Coil Winding.....	Copper
Voice Coil Former.....	Nomex
Cone .....	Paper
Surround.....	Integrated Paper
Dust Dome .....	Non Treated Cloth
Basket .....	Pressed Sheet Steel

### ELECTRICAL CHARACTERISTICS

Nominal Impedance.....	8	Ω
Rated Power (DIN 45573 - IEC 268.5) .....	100	W
Musical Power (DIN 45500) .....	200	W
Sensitivity @ 1 W, 1 m .....	98.8	dB

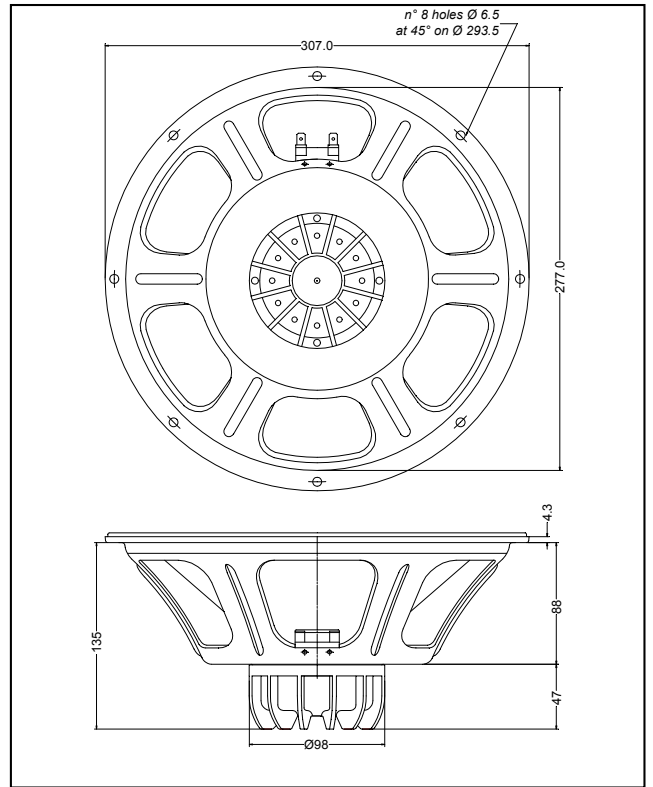

Frequency Response on IEC Baffle (DIN 45575) @ 1 W, 1 m - Impedance

